

ESTATE Rectangular Counter Table (Teak)
EST69



Protective cover available



ADA compliant / wheelchair accessible



Suitable for rooftop



Heavier than regular items, suitable for more windy areas



Assembly



Partially handcrafted, random imperfections are part of the design



Adjustable

DIMENSIONS

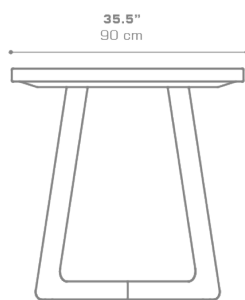
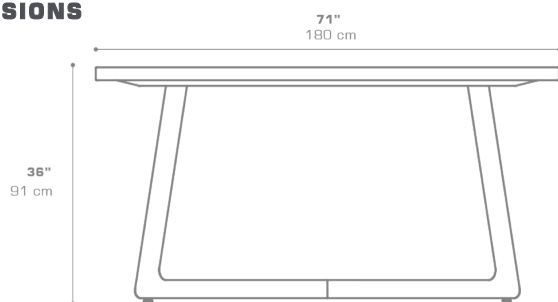

CONFIGURATIONS

FRAME & TOP : Premium Teak | Whitewash

Protective Cover :
EST66PC Top table only
ESTPC-13 Table + 6 Counter Chairs

PACKING DETAILS

NW : 121 lb | 55 kg
GW : 152 lb | 69 kg
VOL : 18 ft³ | 0.51 m³
PU : 2 Boxes

DOWNLOAD MATERIALS

[Teak](#)

ADDITIONAL INFORMATION



6