

TITAN Dining Table 118" / 300 cm (Sintered Stone)
TITO1ST



Protective cover available



ADA compliant / wheelchair accessible

DIMENSIONS

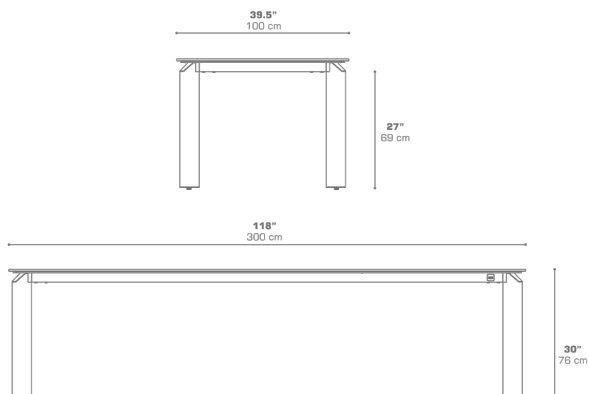

CONFIGURATIONS

FRAME : Powder Coating Aluminum
TOP : Sintered Stone

Protective Cover :
TITO1PC Top table only
TITPC-1 Table + 10 Chairs

PACKING DETAILS

VOL : 34.5 ft³ | 0.98 m³
NW : 350.5 lb | 159 kg
GW : 484 lb | 220 kg
PU : 1 Crate & 2 Boxes

DOWNLOAD MATERIALS

[Powder Coating Colors](#)
[Sintered Stone](#)