

OHANA 2-Seater
OHA05



Protective cover available



Suitable for rooftop



Heavier than regular items, suitable for more windy areas



Partially handcrafted, random imperfections are part of the design

DIMENSIONS

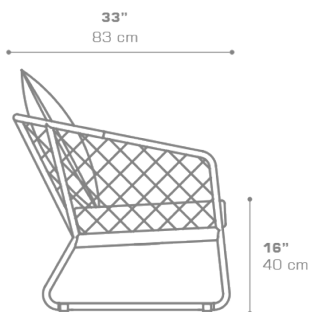
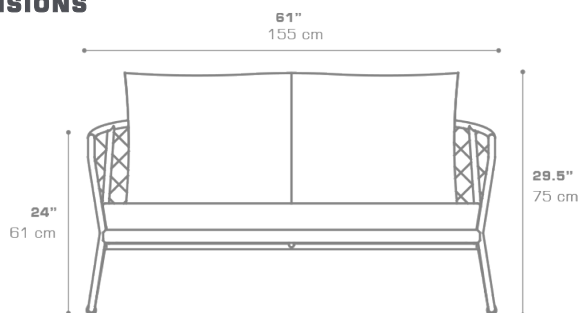

CONFIGURATIONS

- FRAME : Powder Coated Aluminum
- SHELL : Rope Weave
- CUSHION : Grade A | B | C | D | E

Protective Cover :
OHA05PC

PACKING DETAILS

- VOL : 41 ft³ | 1.15 m³
- NW : 46 lb | 21 kg
- GW : 71 lb | 32 kg
- PU : 1 Box
- COM : 4.5 ly

DOWNLOAD MATERIALS

- [Powder Coating Colors](#)
- [Textiles](#)
- [Rope Weave](#)