

MUNIA MO Island 75" / 190 Cm
MUN011

Protective cover available



Suitable for rooftop



Heavier than regular items, suitable for more windy areas

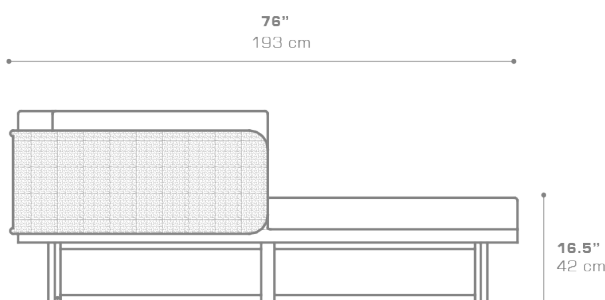
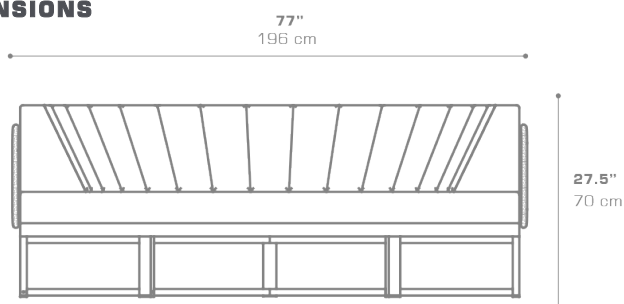

Partially handcrafted, random imperfections are part of the design

DIMENSIONS**CONFIGURATIONS**

| | |
|---------|-------------------------------|
| FRAME | : Powder Coated Aluminum |
| SHELL | : Fiber Weave Flat Patterns |
| CUSHION | : Grade A B C D E |

Protective Cover :
MUN011PC**PACKING DETAILS**

| | |
|-----|---|
| VOL | : 145 ft ³ 4.10 m ³ |
| NW | : 139 lb 63 kg |
| GW | : 496 lb 225 kg |
| PU | : Crate |
| COM | : 11.5 ly |

DOWNLOAD MATERIALS[Powder Coating Colors](#)[Textiles](#)[Weaving Flat Pattern](#)