

MUNIA NAYA Curved Modular System MUN103



Protective cover available



Suitable for rooftop



Heavier than regular items, suitable for more windy areas



Partially handcrafted, random imperfections are part of the design

DIMENSIONS

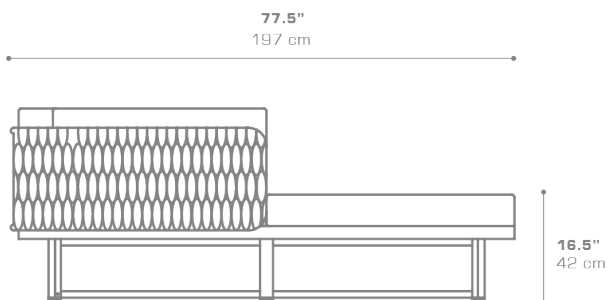
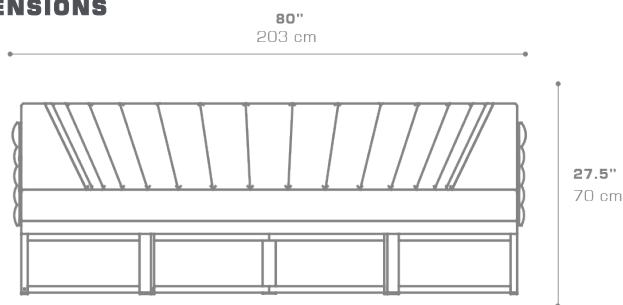

CONFIGURATIONS

FRAME	: Powder Coated Aluminum
SHELL	: Braiding
CUSHION	: Grade A B C D E

PACKING DETAILS

VOL	: 53 ft ³ 1.51m ³
NW	: 71 lb 32 kg
GW	: 106 lb 48 kg
PU	: 1 / box
COM	: 6.5 ly

DOWNLOAD MATERIALS

[Powder Coating Colors](#)

[Textiles](#)

[Braiding](#)