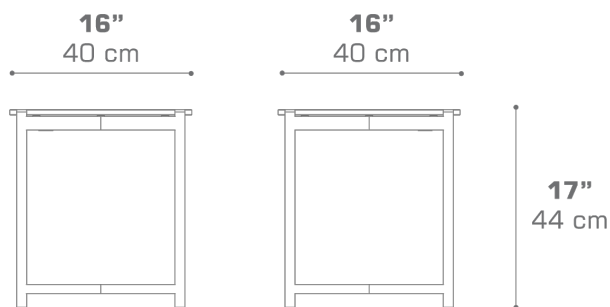

TITAN Side Table 16" / 40 cm (Sintered Stone)
TIT05ST

Protective cover available

DIMENSIONS**CONFIGURATIONS**

FRAME : Powder Coating Aluminum
TOP : Sintered Stone

Protective Cover :
TIT05PC

PACKING DETAILS

VOL : 5 ft³ | 0.13 m³
NW : 13 lb | 6 kg
GW : 28 lb | 12.5 kg
PU : 1 Crate & 1 Box

DOWNLOAD MATERIALS

[Powder Coating Colors](#)
[Sintered Stone](#)