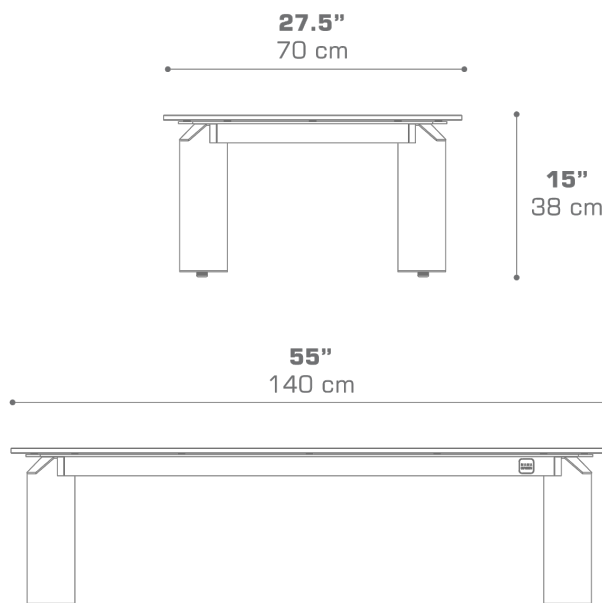

TITAN Coffee Table 55" / 140 cm (Sintered Stone)
TIT03ST

Protective cover available

DIMENSIONS**CONFIGURATIONS**

FRAME : Powder Coating Aluminum
TOP : Sintered Stone

Protective Cover :
TIT03PC

PACKING DETAILS

VOL : 12 ft3 | 0.35 m3
NW : 110 lb | 50 kg
GW : 162.5 lb | 74 kg
PU : 1 Crate & 2 Boxes

DOWNLOAD MATERIALS

[Powder Coating Colors](#)
[Sintered Stone](#)